

H-E-P TURNING VANES & RAIL



manufacturer of
H - E - P Turning Vanes & Rail
High Efficiency Profile

P: (800) 522-2423
F: (941) 473-9320

info@aero-dyne.net
www.aero-dyne.net

Sheet No. HEP-65R2

No other product provides comparable quality, structural integrity and performance

PRODUCT FEATURES

- Generated sound power level does not exceed 54 decibels in band 4 at 2,000 FPM-duct 24 x 24
- Smooth-rounded entry nose and extended trailing edge
- No sharp leading edges to collect debris
- Made in USA
- Product guaranteed against defective material

PRODUCT DESCRIPTION

- Airfoil Blade: 17 point roll-formed process using one piece of 26GA HD Prime Carbon Galvanized steel, furnished in 10 ft. lengths
- Vane Rail: 24GA HD Galvanized steel, assembly slots located on design center spacing of 2.4", furnished in 100 ft. coils
- Fasteners: Ring Shank style screws fasten into continuous channels inside the blade, no annoying rattle, no detaching, no reinforcing rods necessary

ASSEMBLY INSTALL - UNEQUAL ELBOWS

H-E-P turning vanes can be adjusted easily to the proper angle of attack, regardless of the inlet and outlet dimensions of the elbow

1. A narrow strip (approx. 3/4 inch) is sheared from the center of both top and bottom side rail pieces
2. Vanes are attached to rails by the usual method of driving fasteners through the slots
3. All of the vanes in the assembly then move together as the correct alignment is made for the elbow, maintaining the leading and trailing edges in an exactly parallel relationship

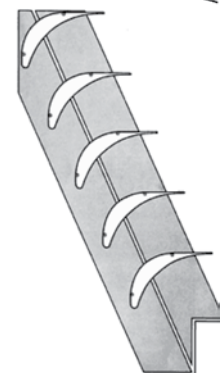
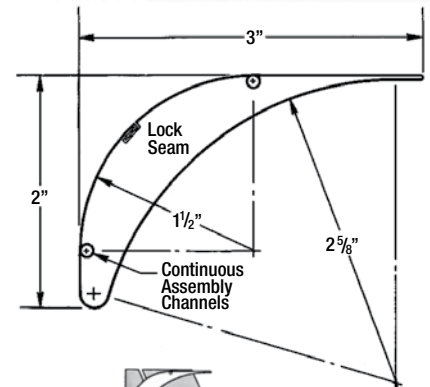
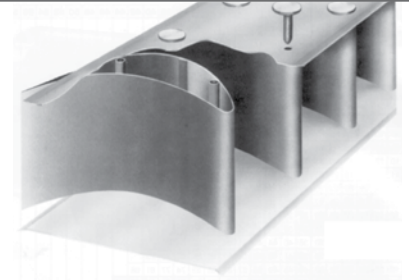

PROJECT:

LOCATION:

CONTRACTOR:

ENGINEER:

APPROVED BY:

DATE:
